



*Products Catalogue*



# Linear Drains

A standout replacement for the standard center drain. Known for its stylish look, adaptability, and durability, it provides an elegant drainage solution. What makes it even more appealing is the exciting option to customize the drain to perfectly fit the dimensions and needs of your space, adding a personal touch that complements your surroundings.



Long Lasting



Easy Setup



Low Maintenance

## Specifications:

Weight:	4.4 kg
Length:	3.0m
Width:	80mm
Depth:	22mm
Material:	Anodized Aluminum
Use:	Indoor and Outdoor

## Xlife Models:

### Stillness Linear Grate



### Stillness Linear Tile Insert





# Stillness Linear Grate

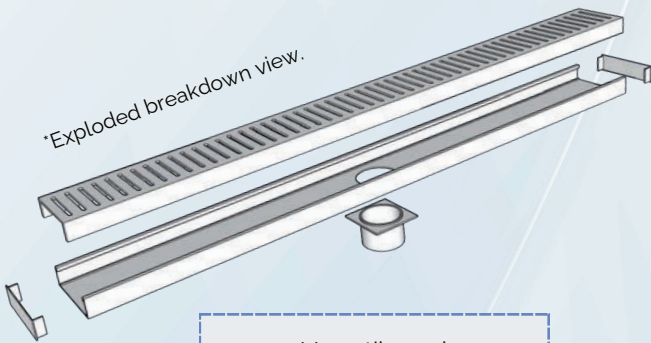

Versatile and customizable, these drains are a tailored masterpiece for your space. Designed for ease, it suits various configurations.

## Colour Options:



Midnight Black  
SKU: XLSLGMB

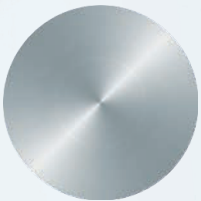

Silk Silver  
SKU: XLSLGSS

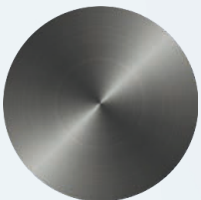

Gunmetal  
SKU: XLSLGGM

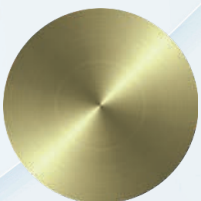

Brushed Brass  
SKU: XLSLGBB

## Key Features

**Built to Last:** Crafted from durable anodized aluminum, the drain is corrosion-resistant, ensuring long-lasting performance.

**Versatility in Use:** Suited for both indoor and outdoor spaces,

**Easy Setup:** Streamlined installation process ensures a hassle-free experience.

**Precision Fit:** Easily adjusts on-site to suit dimensional needs.

**Low Maintenance:** Anodized aluminum and a sleek design make for easy cleaning, preserving the drain's aesthetic appeal with minimal effort over time.

**Flexible Waste Positioning:** Allows for flexible waste positioning along the bottom, eliminating the need for major plumbing adjustments.

**Convenient Cleaning:** Effortless roll-out system facilitates convenient cleaning.

## Accessories:

### Kit Pop Waste

- 1x 50mm Pop Waste + 2 End Caps



# Stillness Linear Tile Insert

\*Exploded breakdown view.

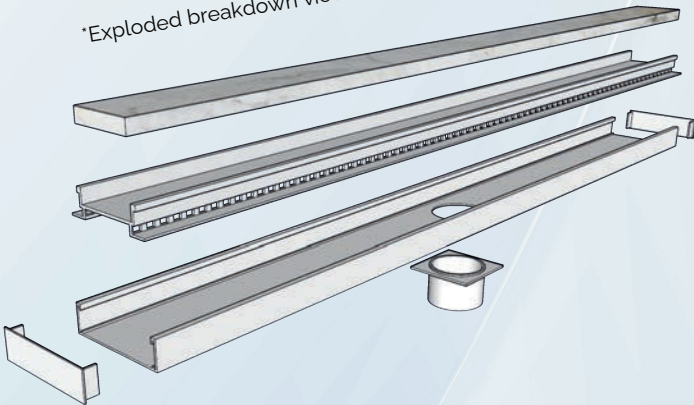

Versatile and customizable, these drains are a tailored masterpiece for your space. A sleek blend of style and function, revolutionizing traditional drains. Its design seamlessly integrates floor tiles and porcelain, offering a subtle, concealed appearance while maintaining the environment's grace.

## Key Features

**Built to Last:** Crafted from durable anodized aluminum, the drain is corrosion-resistant, ensuring long-lasting performance.

**Versatility in Use:** Suited for both indoor and outdoor spaces.

**Seamless Style:** Linear design effortlessly blends with floor tiles for a discreet look that complements any aesthetic.

**Easy Setup:** Streamlined installation process ensures a hassle-free experience.  
**Precision Fit:** Easily adjusts on-site to suit dimensional needs.

**Steady Fit:** Aligns securely with tiles up to 10mm thick, ensuring a seamless blend with the floor.

**Low Maintenance:** Anodized aluminum and a sleek design make for easy cleaning, preserving the drain's aesthetic appeal with minimal effort over time.

## Colour Options:

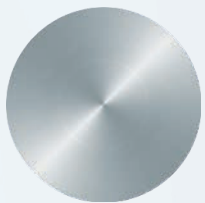

Silk Silver  
SKU: XLSLTISS



Midnight Black  
SKU: XLSLTIMB

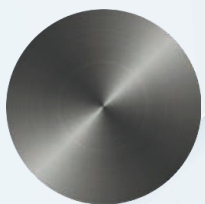

Gunmetal  
SKU: XLSLTGM

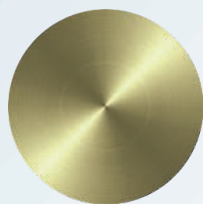

Brushed Brass  
SKU: XLSLTBB

## Accessories:

### Kit Pop Waste

- 1x 50mm Pop Waste + 2 End Caps

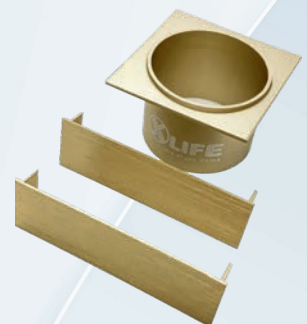

# Square Drains

Elevate your space with this sleek and modern square drain, meticulously designed for both functionality and aesthetics. Its compact form factor ensures seamless integration into any environment, optimizing space without compromising on performance.



Long Lasting



Easy Setup



Low Maintenance

Xlife Models:

## Content Square Grate



### Specifications:

Weight:	0.45 kg
Length:	100 mm
Width:	100 mm
Thickness:	9mm
Material:	Brass
Use:	Indoor

## Content Square 2-in-1

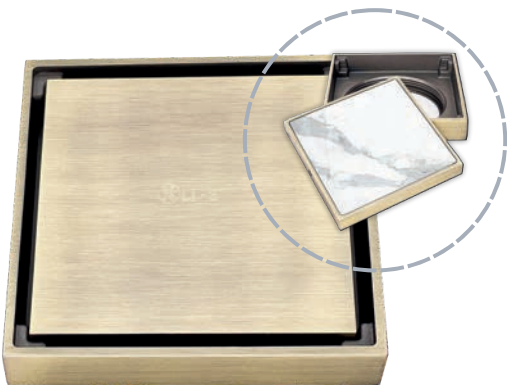

### Specifications:

Weight:	0.45 kg
Length:	100 mm
Width:	100 mm
Thickness:	18mm
Material:	Brass
Use:	Indoor



# Content Square Grate

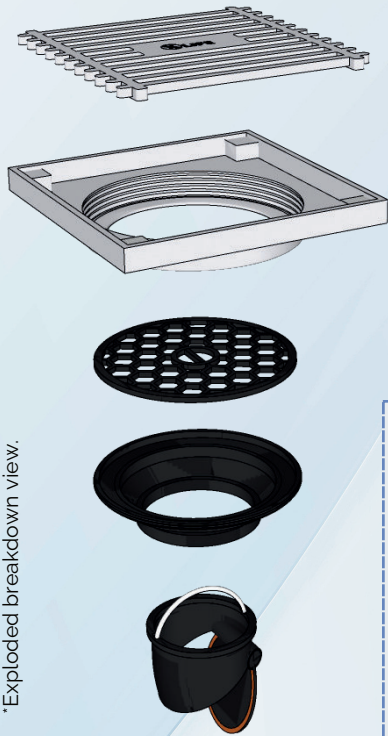

\*Exploded breakdown view.

A harmonious blend of function and form, this floor drain seamlessly integrates into your space, promising both style and superior performance.

## Key Features

**Efficient Water Drainage:** Engineered for effective water flow, preventing water accumulation and minimizing the risk of potential damage.

**High-Quality Construction:** Crafted from premium materials, ensuring durability and longevity for reliable performance.

**Easy Installation:** Simple installation process suitable for both DIY enthusiasts and professional contractors, with clear instructions for hassle-free setup.

**Adaptable Design:** Suited for various architectural styles, making it a versatile choice for bathrooms, kitchens, and other spaces.

**Low Maintenance:** Easy to clean and maintain, offering convenience for regular upkeep and ensuring long-lasting functionality.

## Colour Options:

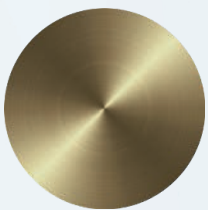

Antique Brass  
SKU: XLCSGAB

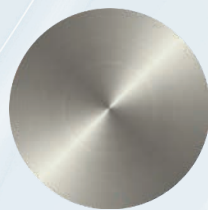

Brushed Nickel  
SKU: XLCSGBN

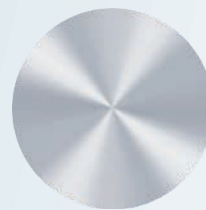

Chrome  
SKU: XLCSGC

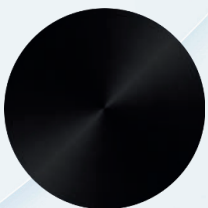

Matte Black  
SKU: XLCSGMB

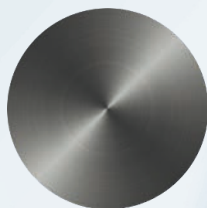

Gunmetal  
SKU: XLCSGGM

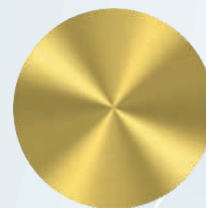

Gold  
SKU: XLCSGG

# Content Square 2-in-1

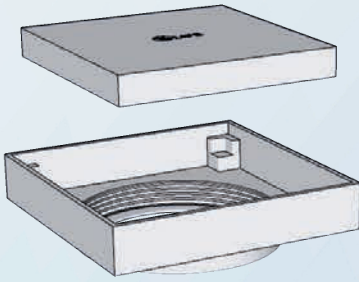

\*Exploded breakdown view.

A groundbreaking blend of style and function. Select either the sleek solid metal face or the tile insert face to elevate your surroundings, achieving a perfect harmony of design and efficiency.

## Key Features

**Dual Functionality:** Versatile design allows for use as a tile insert or a standard drain.

**Seamless Integration:** The tile insert option seamlessly blends with your flooring, creating a cohesive and aesthetically pleasing look.

**Efficient Water Drainage:** Engineered for effective water flow, preventing water accumulation and minimizing the risk of potential damage.

**High-Quality Construction:** Crafted from premium materials, ensuring durability and longevity for reliable performance.

**Easy Installation:** Simple installation process suitable for both DIY enthusiasts and professional contractors, with clear instructions for hassle-free setup.

**Adaptable Design:** Suited for various architectural styles, making it a versatile choice for bathrooms, kitchens, and other spaces.

**Low Maintenance:** Easy to clean and maintain, offering convenience for regular upkeep and ensuring long-lasting functionality.

## Colour Options:

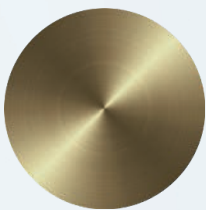

Antique Brass  
SKU: XLCS21AB

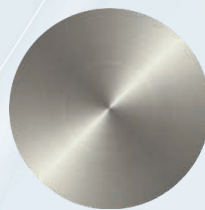

Brushed Nickel  
SKU: XLCS21BN

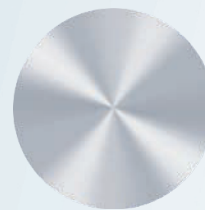

Chrome  
SKU: XLCS21C



Matte Black  
SKU: XLCS21MB

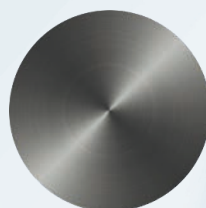

Gunmetal  
SKU: XLCS21GM

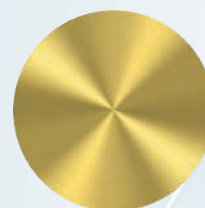

Gold  
SKU: XLCS21G



# Shower Bases

Your go-to solution for waterproofing your bathroom, shower, or wet room before tiling. With excellent water-repellent properties, these boards create a reliable shield against moisture. Their lightweight design and easy-cut features make installation a breeze. You can cover them directly with tiles, render, or plaster, offering a hassle-free process. Plus, their versatility allows installation on nearly all surfaces.



## Key Features

- Easy installation, 10 to 15 minutes and it is ready.
- Fast cure, tiles can be installed after 30 minutes depending on the fixing system.
- It can be installed with a linear drain, square drain or round drain.
- Excellent Thermal Insulation.
- Acoustically better than sand and cement.
- Easy cut to fit all designs.
- Perfect for all surfaces, including existing timber or concrete floors.

## Material:

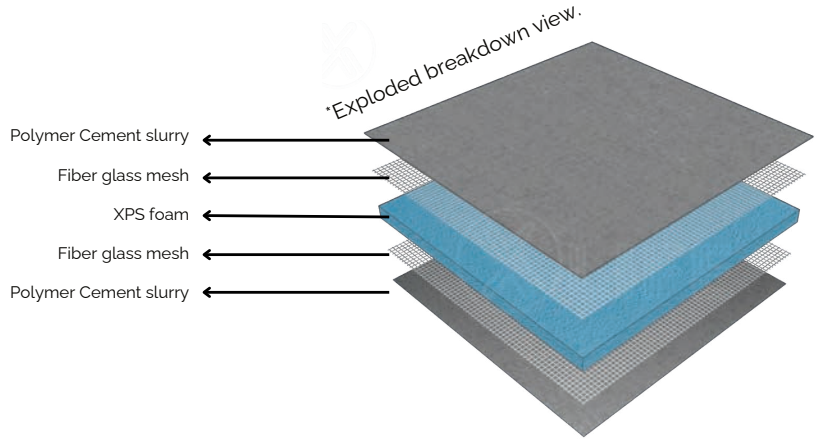

Waterproof



Lightweight



Easy to Install



Thermal Protection



Cost Effective

## Shower Base Centre Drain

XTRAY-C1000X1000

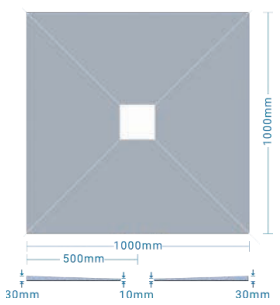

SKU: XTRAY-C1000X1000  
 Length: 1000mm  
 Width: 1000mm  
 Thickness: 30mm

XTRAY-C1200X1200

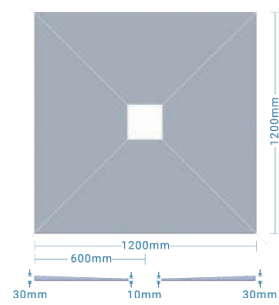

SKU: XTRAY-C1200X1200  
 Length: 1200mm  
 Width: 1200mm  
 Thickness: 30mm



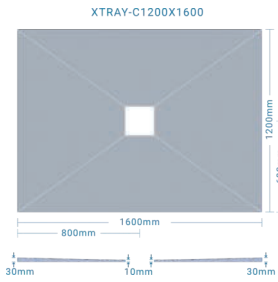

SKU: XTRAY-C1200X1600  
 Length: 1200mm  
 Width: 1600mm  
 Thickness: 30mm

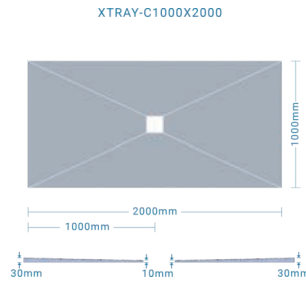

SKU: XTRAY-C1000X2000  
 Length: 1000mm  
 Width: 2000mm  
 Thickness: 30mm

## Shower Base Wedge

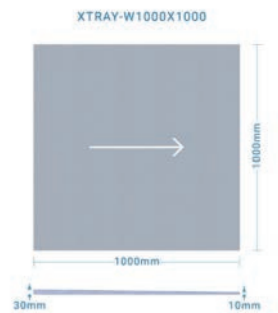

SKU: XTRAY-W1000X1000  
 Length: 1000mm  
 Width: 1000mm  
 Thickness: 30mm

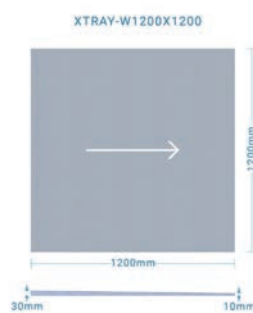

SKU: XTRAY-W1200X1200  
 Length: 1200mm  
 Width: 1200mm  
 Thickness: 30mm

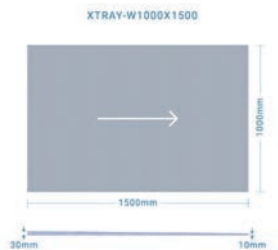

SKU: XTRAY-W1000X1500  
 Length: 1000mm  
 Width: 1500mm  
 Thickness: 30mm

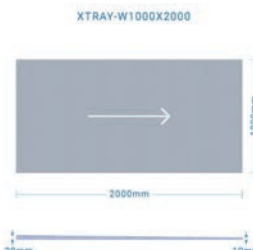

SKU: XTRAY-W1000X2000  
 Length: 1000mm  
 Width: 2000mm  
 Thickness: 30mm

## Shower Hob

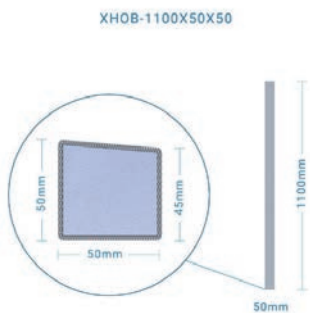

SKU: XHOB-1100X50X50  
 Length: 1100mm  
 Width: 50mm  
 Thickness: 50mm



# Insulation Boards

They are pre-formed trays ready to be tiled over. Made from XPS foam core and strengthened cement fiberglass mesh outside layers, this gives the board strength, rigidity and helps the bond between the tile, adhesive and board.

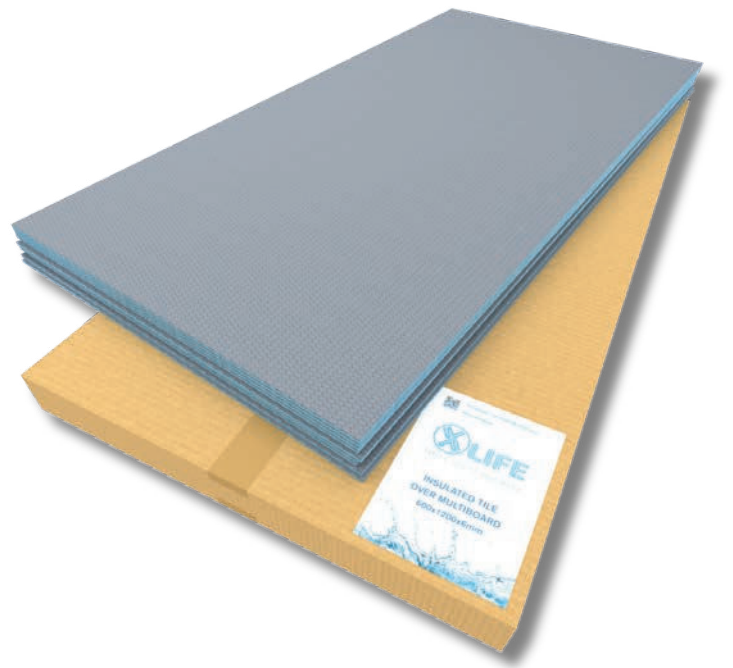

## Key Features

- 100% waterproof, made of HCFC-FREE XPS foam
- High-rigidity and durability
- Close bond to any tiling walls or floors
- Available at various thickness and sizes
- Compatibility to multiple substructures
- Vapor retardant against molds
- Lightweight, easy to handle and cut with utility knife

## Applications

- Attaching to masonry, concrete or plaster
- Screwing onto laths and supports
- Concrete floors
- Timber floors
- Under floor heating
- Bath tubs and shower tray surrounds
- Vanity and shelving
- Pipe coverings

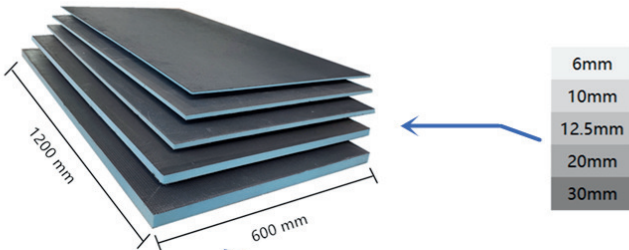

\*Thickness 12.5mm, 20mm and 30mm only available for indent orders.



Waterproof



Lightweight



Easy to Install



Thermal Protection



Cost Effective

## Specifications:

XBOARD-600X1200X6

SKU: XBOARD-600X1200X6

Length: 1200mm

Width: 600mm

Thickness: 6mm

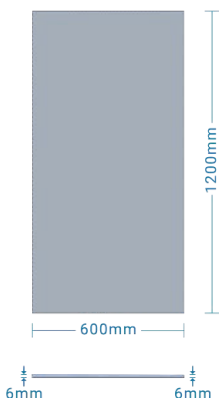

XBOARD-600X1200X10

SKU: XBOARD-600X1200X6

Length: 1200mm

Width: 600mm

Thickness: 10mm

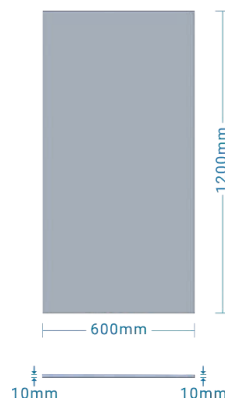



## Shower Niches

### Key Features

- Moisture and rot proof: Ideal for Bathrooms, showers and wetrooms
- High thermal insulation
- Lightweight and workable: Easier and faster to work with than all other types of building board
- Fast cure, tiles can be installed after 30 minutes depending on the fixing system

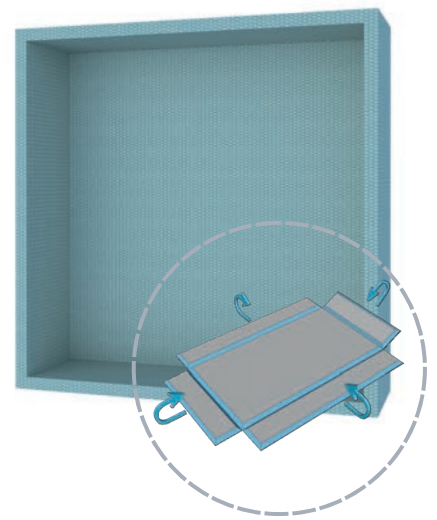

### Specifications:

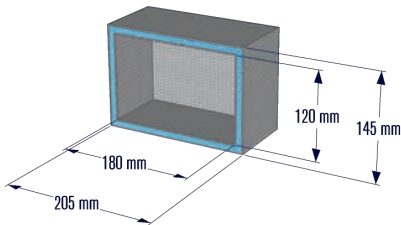

SKU: XNICHE-120x180

Length: 180mm

Width: 120mm

External Dimensions: 145x205mm

Material: XPS + Fiberglass Mesh + Cement Mortar



Waterproof



Lightweight



Easy to Install



Thermal Protection



Cost Effective

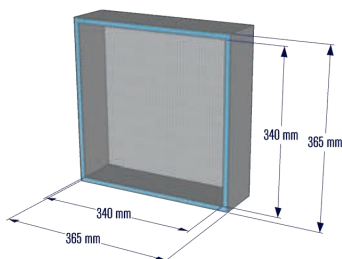

SKU: XNICHE-340x340

Length: 340mm

Width: 340mm

External Dimensions: 365x365mm

Material: XPS + Fiberglass Mesh + Cement Mortar

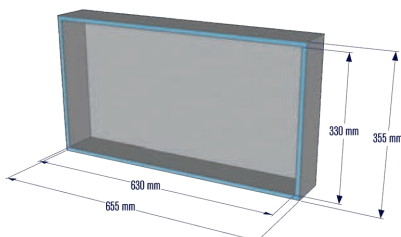

SKU: XNICHE-330x630

Length: 630mm

Width: 330mm

External Dimensions: 355x655mm

Material: XPS + Fiberglass Mesh + Cement Mortar





[xlife.co.nz](https://xlife.co.nz)

*Where Quality meets Innovation*