

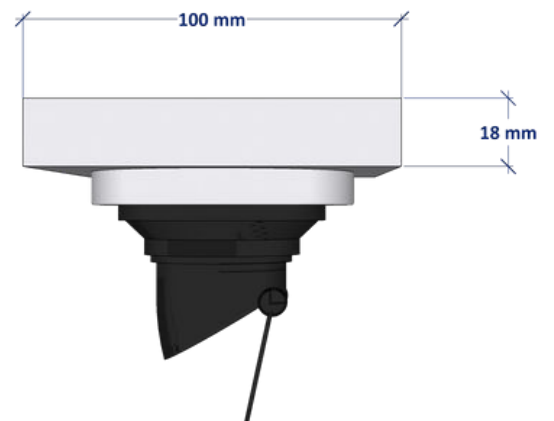

## Technical Specifications CONTENT SQUARE DRAIN 2-IN-1

Product:	Content Square Drain
Brand:	Xlife
Model:	2-in-1
Length:	100mm
Width:	100mm
Thickness:	18mm
Material:	Brass
Use:	Indoor

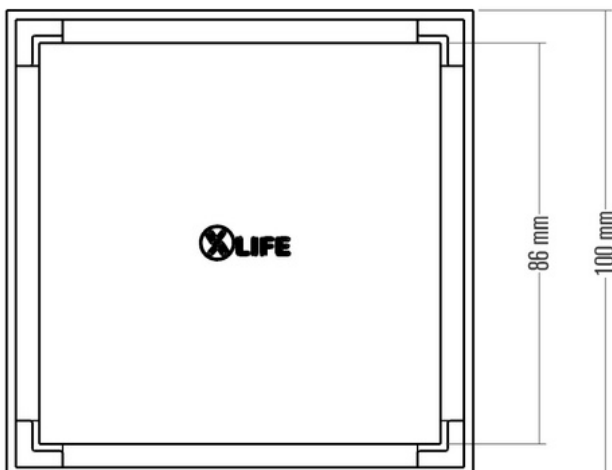

## Colour options:



Antique Brass

SKU: XLCS21AB

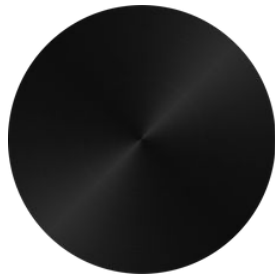

Matte Black

SKU: XLCS21MB

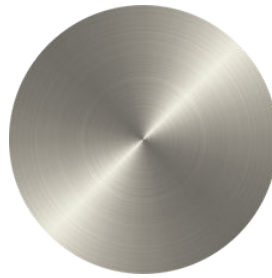

Brushed Nickel

SKU: XLCS21BN

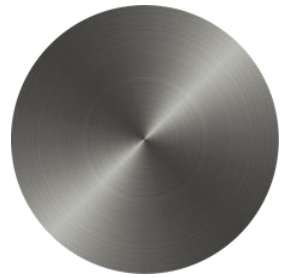

Gunmetal

SKU: XLCS21GM

## Exploded breakdown view:

